



## Design and application

The function of the SGM is based on the variable area float principle. In all cases where a dependable device is required for indicating instantaneous values and monitoring the flow in pipelines, the SGM-PP /-PVC /-PVDF is the obvious choice as a reliable device for measuring the flow of liquids and gases. Since the vertical position of the float is transmitted magnetically to a dial gauge, the SGM, as opposed to standard type variable area flow meters with a glass tube, is also suitable for measuring the flow of opaque media. Each device is individually calibrated to meet customer specifics and fitted with a medium specific scale.

For process control, the flow meter can be equipped with a limit value switch and/or measuring transmitter with electrical analog output.

Our technical documents provide a detailed explanation of the function and measuring principle of VA flow meters.

SGM-PP / -PVC / -PVDF



- **all-plastic device body, indication via magnetic coupling**
- **high chemical resistance**
- **cost-effective alternative to devices with PTFE lining**
- **DN 25 to DN 100**
- **optionally**
  - **limit value switches**
  - **analog output 4 ... 20 mA**
  - **totalizer with LC-Display**





# SGM-PP / -PVC / -PVDF

Variable area flow meters

## Type series

Version	Description
SGM-PP	polypropylene device body
SGM-PVC	polyvinyl chloride device body
SGM-PVDF	polyvinylidene fluoride device body
SGM...-EM	with electrical signal output
SGM...-EMZ	with electrical signal output and totalizer
SGM...-IK1	with one inductive switch (SC3,5-N0-Y)
SGM...-IK2	with two inductive switches (SC3,5-N0-Y)
SGM...-IKS1	with one electronic switch (SB3,5-E2)
SGM...-IKS2	with two electronic switches (SB3,5-E2)
SGM...-IK1-EM	with one inductive switch and with electrical signal output
SGM...-IK2-EM	with two inductive switches and with electrical signal output
SGM...-IKS1-EM	with one electronic switch and with electrical signal output
SGM...-IKS2-EM	with two electronic switches and with electrical signal output

## Technical data

Measurement accuracy	
SGM-PP / -PVC / -PVDF	2,5 acc. to VDI/VDE 3513 pt. 2
Indicator part	
Scale	in phy. units, e.g. l/h, m <sup>3</sup> /h
Scale length	90 mm
Standard range	1:10
Degree of Protection	IP 67, NEMA 4X
Permissible working pressure	
DN 25, DN 50	PN 16
DN 65, DN 80, DN 100	PN 10
Connections	
Flange connection	acc. EN-1092-1, optionally: ANSI B 16.5, JIS B 2220
alternative connection geometries *)	optionally: DIN 11851, DIN EN ISO 228 welding sleeves, glue sleeves

\*) on request

## Materials and media temperature

Version	Measuring tube/float	Media-temperature	Amb. temp.
SGM-PP	Polypropylene	0 ... +80 °C	0 ... +70 °C
SGM-PVC	Polyvinyl chloride	0 ... +40 °C	0 ... +40 °C
SGM-PVDF	Polyvinylidene fluoride	0 ... +100 °C	0 ... +70 °C
Indicator part			
Scale case	aluminium, painted		
Pointer	aluminium, painted		
Scale	aluminium, coated		
Pane	float glass		

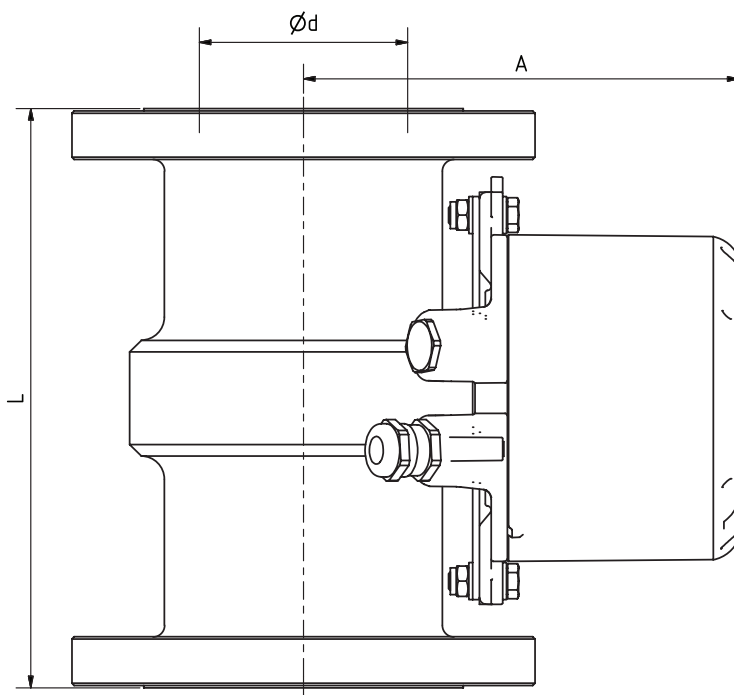
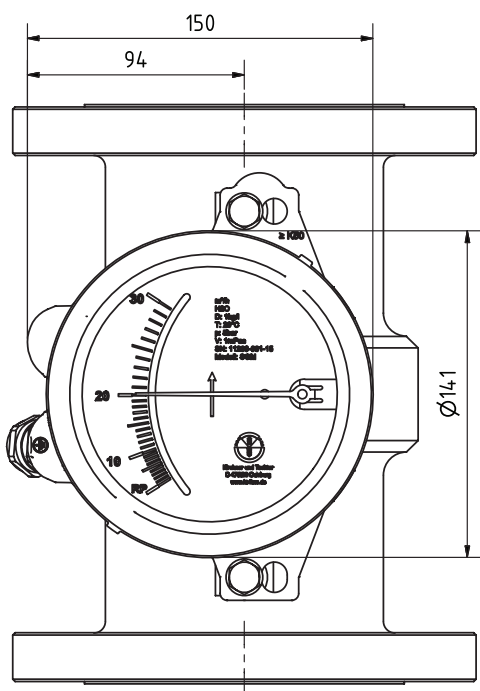

## Dimensions and weights

(Design: Stainless steel with flange connection)

DN	PN	Dimensions [mm]			Weight [kg]		
		L	A	d	PP	PVC	PVDF
25	16	250	158	40	1,8	2	2,4
50	16	250	171	60	2,8	3,2	4,1
65	10	250	185	75	3,6	4	5,2
80	10	250	188	90	4,2	4,9	6,4
100	10	250	200	114	4,8	5,6	7,7

Dimensions for other connection geometries on request

## Measuring ranges

(Data serve as an example. Exact measuring ranges on request.)

DN	H <sub>2</sub> O [m <sup>3</sup> /h]
25	0,25 - 2,5
50	1 - 10
65	1,6 - 16
80	3 - 30
100	4,5 - 45

Measuring ranges for air or gas on request



# SGM-PP / -PVC / -PVDF

Variable area flow meters

## Safety note

Operate the devices only up to the specified permissible working pressure and operating temperature.  
Avoid excessive pressure surges.

## Proper use

The user is responsible for assessing the suitability of the flow meters for his case of application, for use as prescribed and for material compatibility regarding the liquid product used in his process. The manufacturer shall not be liable for any damage arising from incorrect or improper use of the devices.

## Conformity with EU Directives

The SGM variable area flow meter meets all requirements of EU Directives applicable to the product.

- EMC-Directive (2014/30/EU)
- PED (2014/68/EU)

The equipment from **Kirchner und Tochter** has been tested in compliance with applicable CE-regulations of the European Community. The respective declaration of conformity is available on request. Subject to change without notice. The current valid version of our documents can be found at [www.kt-flow.de](http://www.kt-flow.de).

The **Kirchner und Tochter** QM-System is certified in accordance with DIN EN ISO 9001:2015. The quality is systematically adapted to the continuously increasing demands.